

34977 REPLACEMENT TEE

FOR 34970 AIR•VAC

⚠ WARNING ⚠



• Wear safety goggles when working with refrigerants. Refrigerants can cause eye injury.



• Disconnect hoses using extreme caution! Pressurized refrigerant may be present in hoses. Point hoses away from you and anyone nearby.

The 34977 tee inlet allows you to use either R-12 or R-134a refrigerant. Follow these instructions to assemble the 1/2" x 1/4" flare tee on your Air•Vac:

1. Steady the Air•Vac by placing it in a vise while removing the old fitting (callout (1) in the illustration).
2. If the extension tube (2) comes off with the fitting, hold the tube in the vise (taking care not to crush the tube) and unthread the fitting. Make sure the washer (4) stays with the tube.
3. Apply pipe thread sealant on both ends of the extension tube (2) and thread the new fitting (3) onto the extension tube until finger tight.
4. Insert the extension tube into the housing (6) with the washer (4) on the outside of the housing. Thread the tube into the vacuum block (5) until finger tight.
5. Hold the Air•Vac steady in the vise. Tighten the new fitting until the assembly is snug but does not bow the housing (6). *Note: You might need to use a 5/8" wrench to steady the inlet fitting (7).*

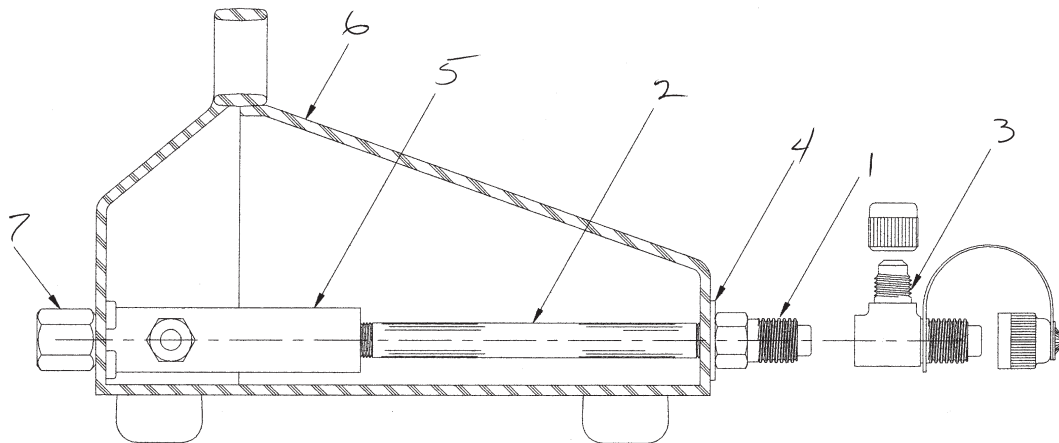

For more information, call **TOLL-FREE**
1-800-822-5561 in the continental U.S. and Canada.
In all other locations, contact your local distributor.

Because of ongoing product improvements, we reserve the right to change design, specifications, and materials without notice.

ROBINAIR

655 EISENHOWER DRIVE
OWATONNA MN 55060
CUSTOMER SERVICE : 1-800-533-6127
FAX : 1-800-322-2890
TECHNICAL SERVICE : 1-800-822-5561
FAX : 1-866-259-1241
WEBSITE : WWW.ROBINAIR.COM